

Chevy LS1 Race Series SFD52 Throttle body kit



Brand: Jenvey
Product Code: CKCT01
Availability: In Stock
Weight: 12.00kg
Dimensions: 60.00cm x 50.00cm x
30.00cm

Price: \$7,450.00

Short Description

The ideal choice for atmo circuit and race LS1 engines. This ITB kit boosts mid range and top end torque and power while providing

Description

Chevrolet LS1 and LS6 ITB throttle body kit from Jenvey Dynamics includes

- Eight SFD52/0/0 throttle bodies with an operating wheel linkage,
- Two EFI inlet manifolds
- Two fuel rails
- Eight 60mm long airhorns.

This is for the LS1LS6 "cathedral port" engine from the Generation III family.

Kit contents

Jenvey Manifold (CT01)

Eight SFD52 race throttle bodies

Eight 60mm long aluminum trumpets

Linkages

Fuel Rails (Suits Bosch std length injectors)

Dyno graphs

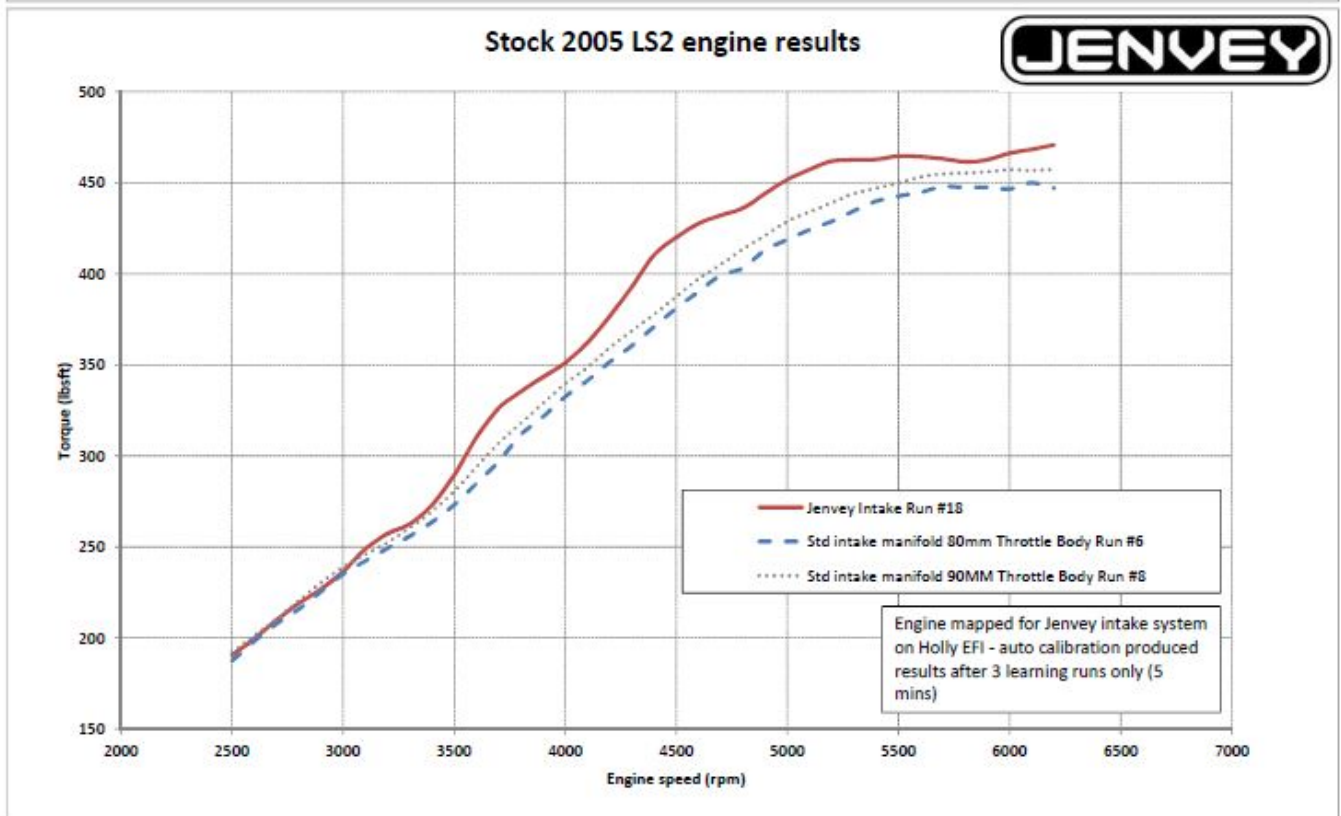
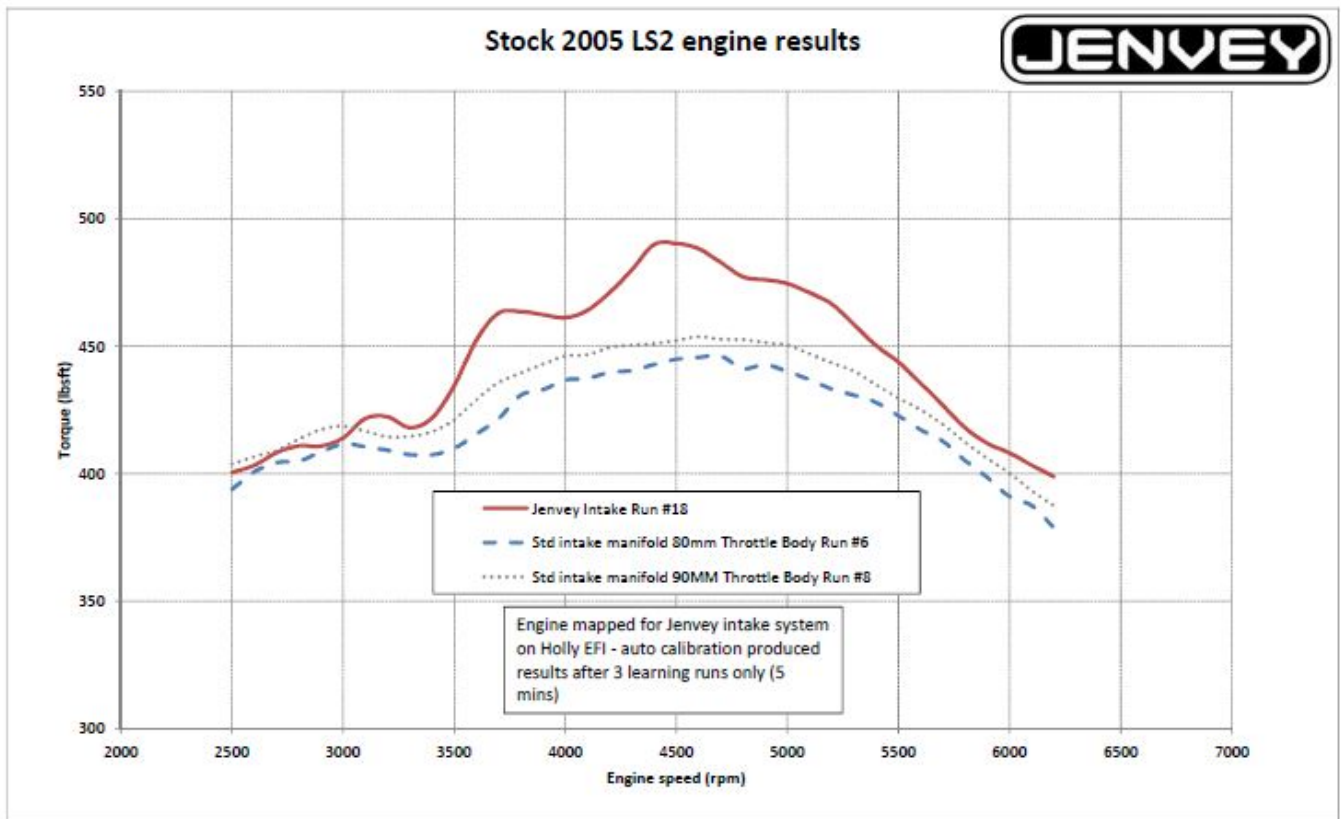

Drawings

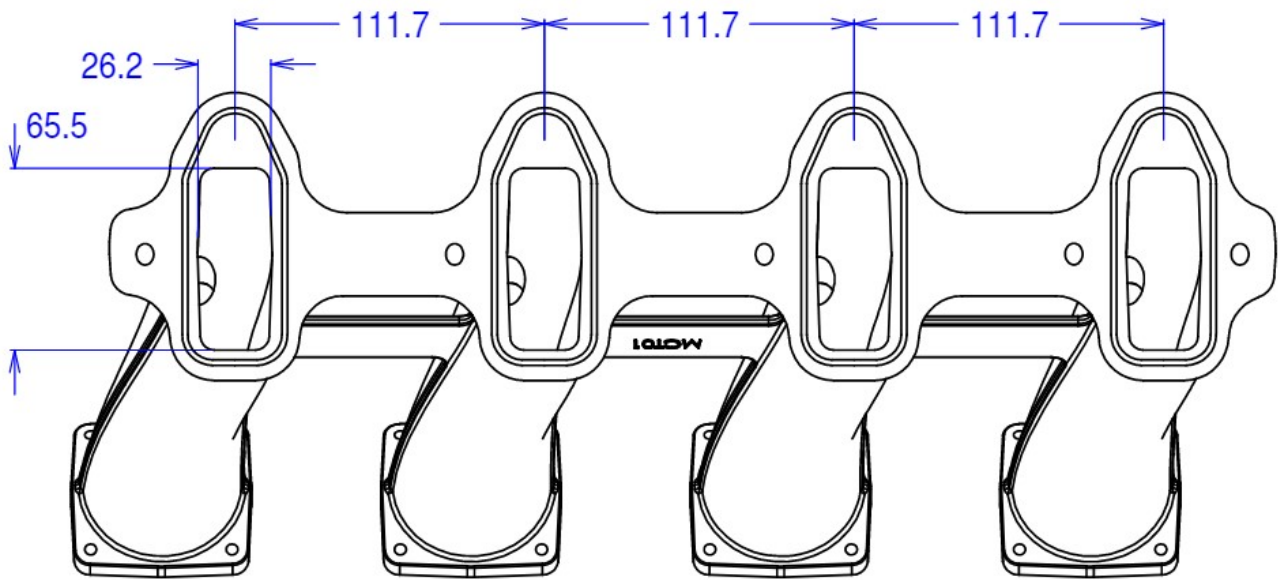

Specification

Make	
General Motors	LS1
General Motors	LS2
General Motors	LS6